

Structural Composition

The HG series I plate heat exchanger is composed of a set of herringbone metal corrugated plates with openings, which form a liquid flow channel, and heat will be transferred between the two liquids. This group of corrugated plates is assembled between a fixed plate and a movable compression plate, and is compressed by clamping bolts.

These plates are equipped with sealing gaskets, which seal the channels between the plates and allow liquid to flow alternately into adjacent channels. The plate and the movable plate are fixed between the upper and lower rods, and the guide rod is fixed on the upright column.

By means of counter-flow, the hot side medium transfers thermal to the cold side medium through plates between channels, and the media do not mix with each other. For the one pass solution design, all connections are on the fixed frame side which will easier the plate heat exchanger installation and disassembling. For cleaning and repair, only the heat exchanger needs to be disassembled for repair, not the pipes.

Recommended Applications

HFM plate heat exchanger HG series II can be specially used for heating or cooling in some specific fields. For example, HG0215D , HG0222C , HG0224B , HG0234C and other models are very suitable for heating and cooling of HVAC, industrial circulating water, and HG0215B , HG0222A , HG0224A and other models are very suitable for steam condensing conditions.

Flow Plate

The plate design has two corrugated forms: horizontal corrugated and vertical corrugated. They can meet different pressure drop requirements and suit for different working conditions media.

The corrugated “herringbone” pattern makes more contact points between plates bearing more uniform pressure and ensures turbulent flow in the whole effective area.

The food-grade heat exchanger has a food-grade frame, which is safer and more hygienic.

Compared with traditional shell-and-tube heat exchangers, it has higher heat transfer efficiency and occupies less space.

Quality after-sales service.

Technical Parameters

Construction Standard	Design Pressure (barg)	Max. Design Temperature °C	Construction Standard
Carbon Steel/Stainless Steel	PED	10.0/16.0	180
	ASME	10.0/16.0	180

- Painted frame, color RAL 5002 (available in other colors)
 - Stainless steel frame, designed for the food and dairy industry.
- Both frames come with clamping bolts placed around the frame edge.



Data Required for Correct Quotation

- Types of Media
- Working Pressure
- Pressure Loss
- Thermodynamic properties
- Temperatures
- Flow rates

Above data determines the choice of heat exchanger.

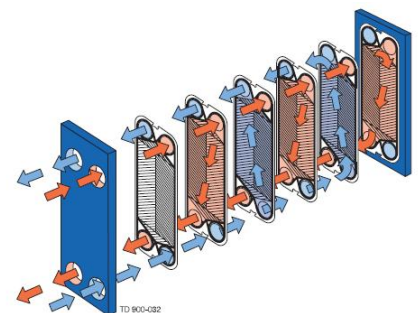

Interface information

Metal bushings (stainless steel, titanium or other materials), welding flanges, threaded pipes, clamps, etc.

Other forms of interfaces can be made according to

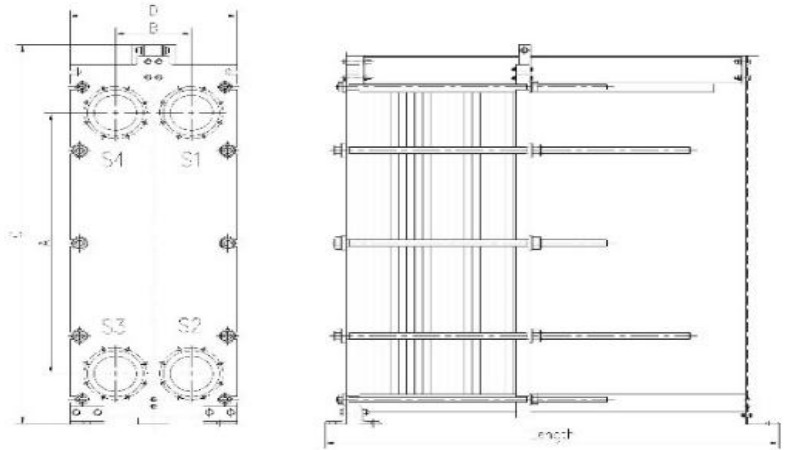

Type	Interface size	A/ mm	B/ mm	C/ mm	D/ mm	Length Max./ mm	Maximum flow / m3/h
HG0215B	DN50	371	130	670	323	1045	40
HG0215C	DN50	743	130	1020	323	1045	40
HG0215D	DN50	1115	130	1390	323	1045	40
HG0222A	DN100	708	262	1110	540	2286	140
HG0222B	DN100	1113	262	1607	540	3196	140
HG0222C	DN100	1519	262	2103	540	3196	140
HG0224A	DN150	1092	314	1666	640	2596	280
HG0224B	DN150	1572	314	2146	640	2596	280
HG0234A	DN250	1406	420	2170	895	3217	280
HG0234B	DN250	1703	420	2467	895	3817	800
HG0234C	DN250	2000	420	2764	895	3817	800
HG0245A	DN350	1698	565	2617	1136	4925	1700
HG0245B	DN350	2035	565	2954	1136	4925	1700

Plate	Material	Applicable Mediums	Thickness
	304SS	Pure water/ Edible oil/ Ethanol	0.4/ 0.5/ 0.6
	316SS	Water/ Edible oil/ Ethanol/ Carbonic acid/ 30% Sulphuric acid	0.4/ 0.5/ 0.6
	254SMO	Saline / Inorganic acid	0.6
	Titanium	Sea water/ 130°C Chloride	0.5/ 0.6
	Hastelloy C-276	Organic acid / High temperature HF acid / Hydrochloric acid (< 40%) / Phosphoric acid (< 50%) / Chloride / Fluoride	0.6
	Nickle 200/201	High temperature 50~70% Alkali	0.6

Gasket	Material	Applicable Mediums	Temperature/ °C
	EPDM Ethylene propylene diene monomer	Water/ Steam/ Edible oil	-25-150
	NBR Nitrile rubber	Water/ Edible oil/ Mineral oil/ Ethanol/ Ethylene glycol	-25-130
	FPM/Viton Fluoro rubber	High concentration inorganic acid (oxidizing acid, etc.) / Hot water and steam / High temperature mineral oil	-20-180
	CR Chloroprene rubber	Ammonia and various fluorine-containing refrigerants	-40-125