

Design Principle

HG0115A/B plate range with length 0.75m, will cover many duties up to 50m³/h in a single pass solution, satisfying many applications requirement.

By means of countercurrent flow, the hot side medium transfers thermal to the cold side medium through plates between channels. And the media do not mix with each other to achieve optimal heat exchange efficiency.

For the one pass solution design, all connections are on the fixed frame side which will easier the plate heat exchanger installation and disassembling. When do cleaning and maintenance jobs, no need to remove the pipes.

Recommended Applications

The plate heat exchangers of the HG0115 series are designed for high pressure. They can be used for heating and cooling operations in multiple areas, steam condensation, milk pasteurization, industrial circulating water cooling and other clear media's heating and cooling.

HG0115A/B plate heat exchanger's multi-section design for milk pasteurization has the advantages in less space taking, more efficient heat transfer, and economic cost control.

Flow Plate

The plate design has two corrugated forms: horizontal corrugated and vertical corrugated. The plates can meet different pressure drop requirements and suit for different working conditions media. The corrugated "herringbone" pattern makes more contact points between plates bearing more uniform pressure and ensures turbulent flow in the whole effective area.



Data Required for Correct Quotation

- Types of Media
- Working Pressure
- Pressure Loss
- Thermodynamic properties
- Temperatures
- Flow rates

Above data determines the choice of heat exchanger.

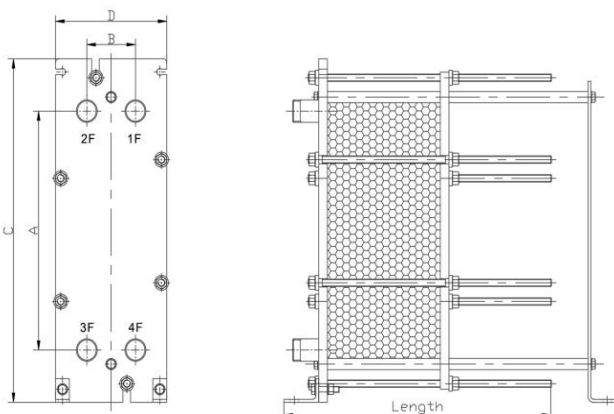

A/ mm	B/ mm	C/ mm	D/ mm	Length Max./ mm
640	140	920	320	1715

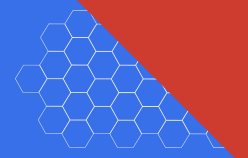

Connection	Construction Standard	
DN50	Carbon Steel/Stainless Steel/ Titanium	Weld neck flange
		Pipe/ Threaded pipe

Frame	Construction Standard		Design Pressure (barg)	Max. Design Temperature °C
	Carbon Steel/Stainless Steel	PED	10.0/16.0	180
		ASME	10.0/16.0	180

■ Other connections available on request.

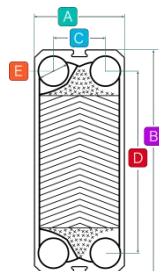

/mm
 A= 248
 B= 747
 C= 140
 D= 640
 E= 59

- Painted frame, color RAL 5002 (available in other colors)
- Stainless steel frame, designed for the food and dairy industry.

Both frames come with clamping bolts placed around the frame edge.

Plate	Material	Applicable Mediums	Thickness
	304SS	Pure water/ Edible oil/ Ethanol	0.4/ 0.5/ 0.6
	316SS	Water/ Edible oil/ Ethanol/ Carbonic acid/ 30% Sulphuric acid	0.4/ 0.5/ 0.6
	254SMO	Saline / Inorganic acid	0.6
	Titanium	Sea water/ 130°C Chloride	0.5/ 0.6
	Hastelloy C-276	Organic acid / High temperature HF acid / Hydrochloric acid (< 40%) / Phosphoric acid (< 50%) / Chloride / Fluoride	0.6
	Nickle 200/201	High temperature 50~70% Alkali	0.6

Gasket	Material	Applicable Mediums	Temperature/ °C
	EPDM Ethylene propylene diene monomer	Water/ Steam/ Edible oil	-25-150
	NBR Nitrile rubber	Water/ Edible oil/ Mineral oil/ Ethanol/ Ethylene glycol	-25-130
	FPM/Viton Fluoro rubber	High concentration inorganic acid (oxidizing acid, etc.) / Hot water and steam / High temperature mineral oil	-20-180
	CR Chloroprene rubber	Ammonia and various fluorine-containing refrigerants	-40-125