

## Design Principle

HG0222 plate range with length 0.9-1.7m, will cover many duties up to 140m<sup>3</sup>/h in a single pass solution, satisfying many applications requirement.

By means of countercurrent flow, the hot side medium transfers thermal to the cold side medium through plates between channels. And the media do not mix with each other to achieve optimal heat exchange efficiency.

For the one pass solution design, all connections are on the fixed frame side which will easier the plate heat exchanger installation and disassembling. When do cleaning and maintenance jobs, no need to remove the pipes.

## Recommended Applications

The plate heat exchangers of the HG0222 series are designed for high pressure. They can be used for heating and cooling operations in multiple areas, steam condensation, industrial circulating water cooling and other clear media's heating and cooling.

## Flow Plate

The plate design has two corrugated forms: horizontal corrugated and vertical corrugated. The plates can meet different pressure drop requirements and suit for different working conditions media. The corrugated "herringbone" pattern makes more contact points between plates bearing more uniform pressure and ensures turbulent flow in the whole effective area.



## Data Required for Correct Quotation

- Types of Media
- Working Pressure
- Pressure Loss
- Thermodynamic properties
- Temperatures
- Flow rates

*Above data determines the choice of heat exchanger.*

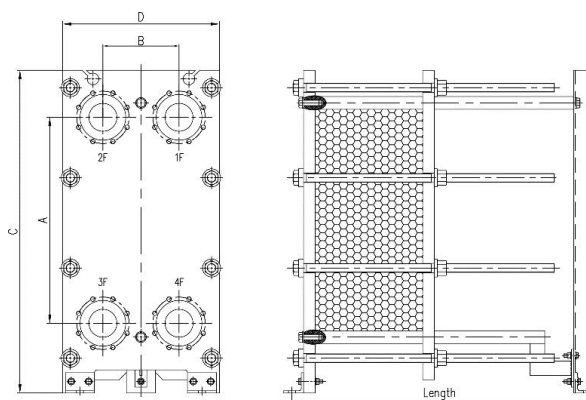

|         | A/ mm | B/ mm | C/ mm | D/ mm | Length Max./ mm |
|---------|-------|-------|-------|-------|-----------------|
| HG0222A | 707   | 262   | 1110  | 540   | 2225            |
| HG0222B | 1113  |       | 1607  |       | 3135            |
| HG0222C | 1519  |       | 2013  |       | 3200            |

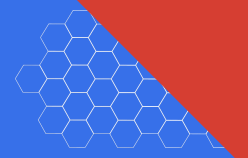

| Connection | Construction Standard                  |                     |
|------------|--|---------------------|
| DN100      | Carbon Steel/Stainless Steel/ Titanium | Weld neck flange    |
|            |  | Pipe/ Threaded pipe |

■ Other connections available on request.

| Frame | Construction Standard        |      | Design Pressure (barg) | Max. Design Temperature °C |
|-------|------------------------------|------|------------------------|----------------------------|
|       | Carbon Steel/Stainless Steel | PED  | 10.0/16.0              | 180                        |
|       |                              | ASME | 10.0/16.0              | 180                        |

- Painted frame, color RAL 5002 (available in other colors)
  - Stainless steel frame, designed for the food and dairy industry.
- Both frames come with clamping bolts placed around the frame edge.

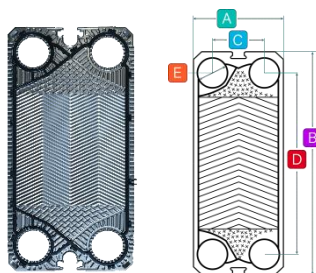

| /mm | HG0222A | HG0222B | HG0222C |
|-----|---------|---------|---------|
| A   | 445     |         |         |
| B   | 897     | 1303    | 1709    |
| C   | 262     |         |         |
| D   | 707     | 1113    | 1519    |
| E   | 110     |         |         |

| Plate | Material        | Applicable Mediums  | Thickness     |
|-------|-----------------|---|---------------|
|       | 304SS           | Pure water/ Edible oil/ Ethanol   | 0.4/ 0.5/ 0.6 |
|       | 316SS           | Water/ Edible oil/ Ethanol/ Carbonic acid/ 30% Sulphuric acid   | 0.4/ 0.5/ 0.6 |
|       | 254SMO          | Saline / Inorganic acid   | 0.6           |
|       | Titanium        | Sea water/ 130°C Chloride   | 0.5/ 0.6      |
|       | Hastelloy C-276 | Organic acid / High temperature HF acid / Hydrochloric acid (< 40%) / Phosphoric acid (< 50%) / Chloride / Fluoride | 0.6           |
|       | Nickle 200/201  | High temperature 50~70% Alkali  | 0.6           |

| Gasket | Material                                 | Applicable Mediums  | Temperature/ °C |
|--------|--|---|-----------------|
|        | EPDM<br>Ethylene propylene diene monomer | Water/ Steam/ Edible oil  | -25-150         |
|        | NBR<br>Nitrile rubber                    | Water/ Edible oil/ Mineral oil/ Ethanol/ Ethylene glycol  | -25-130         |
|        | FPM/Viton<br>Fluoro rubber               | High concentration inorganic acid (oxidizing acid, etc.) / Hot water and steam / High temperature mineral oil | -20-180         |
|        | CR<br>Chloroprene rubber                 | Ammonia and various fluorine-containing refrigerants  | -40-125         |