

Installation, Operation, and Maintenance Manual
Semi-Welded Plate Heat Exchangers

HW01 series

Table of Contents

Preface.....	2
Description.....	3
Main components	3
Name plate	4
Function	5
Installation	6
Before installation	6
Requirements	6
Lifting	7
Raising	8
Connecting to system	9
Operation	10
Start-up	10
Unit in operation	11
Shut-down	11
Maintenance	12
Cleaning-In-Place (CIP)	12
Manual cleaning	13
Regasketing	17
Closing	19
Pressure test after maintenance	21
Storage of the SWHE	22

This manual provides information needed to install, operate and carry out the maintenance of the Semi-Welded Plate Heat Exchanger (SWHE).

Safety considerations

The Semi Welded Plate Heat Exchanger shall be used and maintained in accordance with HFM's instructions in this manual. Faulty handling of the heat exchanger may result in serious consequences with injuries to persons and/or property damage. HFM will not accept responsibility for any damage or injury that has resulted from not following the instructions in this manual.

The heat exchanger shall be used in accordance with the specified configuration of material, media types, temperatures and pressure for the specific Semi-Welded Plate Heat Exchanger.

The following models are covered in this manual:

HW0115A	HW0122A	HW0124A	HW0133A
HW0133B	HW0133C	HW0145A	

Warranty conditions

The warranty conditions are usually included in the signed sales contract prior to the order of the delivered SWHE. Alternatively, the warranty conditions are included in the sales offer documentation or with a reference to the document specifying the valid conditions. If faults occur during the specified warranty period, always consult HFM for advice.

Report the date when the heat exchanger was put into operation to HFM.

Advice

Always consult HFM for advice on:

- New plate pack clamping size if you intend to change the number of Cassettes (Twin plates).
- Selection of gasket material if operating temperatures and pressures are permanently changed, or if another medium is to be processed in the SWHE.
- Loosen the tightening bolts. Follow the instructions "Opening" .
- Re-tighten according to the instructions "Closing" .

Main components

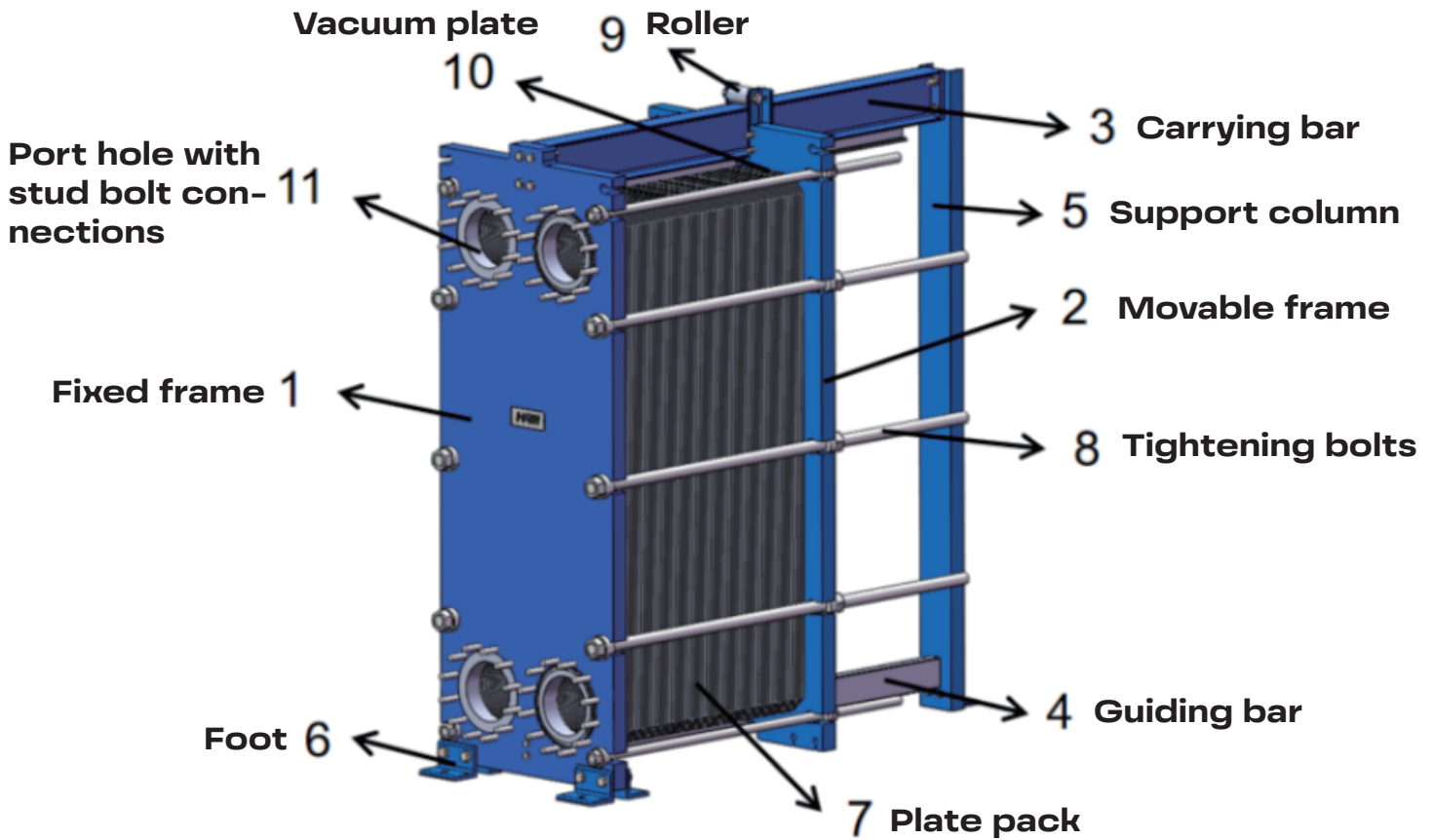

1.Fixed frame with a number of port holes for the connection of the piping system. The carrying and guiding bars are supported by the fixed frame.
2.Movable frame that can contain a number of port holes for the connection of the piping system.
3.Carries the plate pack and the pressure plate.
4.Keeps the channel plates and the movable frame in line at their lower end. When both the carrying and guiding bars are round bars, the guiding bar will bear the weight of the plate pack.
5.Supports carrying and guiding bars.
6.Connect the heat exchanger to its foundation.
7.Heat is transferred from one medium to the other through the plates. The plate pack consists of semi-welded plates in pairs which form a cassette (twin plate) and gaskets.
8.Compress the plate pack between the frame and pressure plate.
9.Large units will use rollers. Make the movable frame roll smoothly on the carrying bar.
10.When considering vacuum in the design pressure, a vacuum plate will be used.
11.Port holes through the frame plate allow the media to enter into or exit from the heat exchanger. Different types of connections can be used to connect the piping system to the apparatus.The port holes may be protected against corrosion by metal linings.

Name plate

On the name plate the manufacturing number, model, clamping size and manufacturing year can be found. The name plate is fixed to the frame plate, most common, or the pressure plate.

The mechanical design pressure and the design temperature as given on the name plate are the values to which the plate heat exchanger is approved to the pressure vessel code in question. The mechanical design temperature may exceed the maximum operating temperature established for the gasket material lifetime. If the operating temperatures as specified on the assembly drawing or data sheet are to be exceeded the supplier should be consulted.



Warning!

For each unit, the mechanical design pressures and temperatures are marked on the name plate. These must not be exceeded.

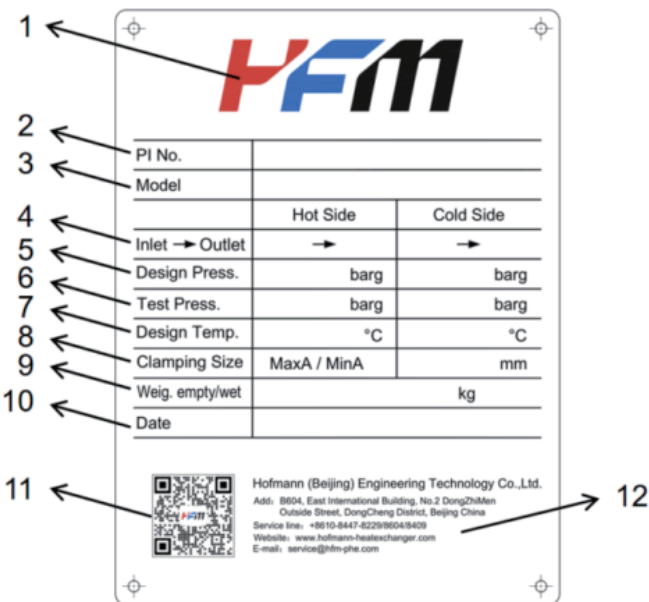

1. Space for logotype.

2. PI No..

3. Model.

4. Locations of connections for each fluid.

5. Design pressure.

6. Test pressure.

7. Design temperature.

8. Clamping size.

9. Weight empty / wet(full of water).

10. Year of manufacture.

11. QR code.

12. Manufacturer's name and information.

Function

The Semi welded Plate Heat Exchanger (SWHE) consists of a set of corrugated metal plates with port holes for inflow and outflow of two separate fluids.

The plates are arranged as cassettes (twin plates) in such a way that every second channel is welded, and every other channel is gasketed. The heat transfer between the two fluids will take place through the plates. The cassette concept gives rise to two different type of channels - welded channels used for the aggressive primary media and gasketed channels used for the non-aggressive secondary media. The plate pack is assembled between a fixed frame and a movable frame and compressed by tightening bolts. The plates are fitted with a gasket that seals the channel and directs the fluids into alternate channels. The plate corrugation promotes fluid turbulence and supports the plates against differential pressure.

Before installation

On the name plate the manufacturing number, model, clamping size and manufacturing year can be found. The name plate is fixed to the frame plate, most common, or the pressure plate.



Note!

Before start-up, check that all tightening bolts are firmly tightened and that the correct measurements of the plate pack are used.

- To avoid water hammer, do not use fast-closing valves.
- Safety valves should be installed according to current pressure vessel regulations.
- If the SWHE surface temperature is expected to be hot or cold, the heat exchanger should be insulated.
- It is recommended that protective sheets are used to cover the plate pack.
- For each model, design pressures and temperatures are marked on the name plate. These must not be exceeded.
- Full vacuum conditions shall apply at start up for refrigeration duties to avoid moisture and air in the heat exchanger.

Requirements

Space

A minimum free space is needed for lifting cassettes in and out. Refer to the delivered drawing or minimum equivalent to the frame width.

Foundation

Install on a flat foundation giving enough support to the frame.

Elbow

To allow easier disconnection of the SWHE, an elbow should have a flange for connection in the movable frame, directed upwards or sideways, and with another flange located just outside the contour of the heat exchanger.

Shut-off valve

To be able to open the SWHE, shut-off valves should be installed at all connections.

Drip tray (optional)

Depending on the type of fluid in the SWHE and the type of installation, a drip tray (drainage box) may be necessary to avoid injury to personnel and damage to equipment.



Note!

Put the drip tray in place before positioning the SWHE.

Ensure the plate pack is tightened to the correct dimension A (check SWHE drawing or name plate) before the pipe system is connected.

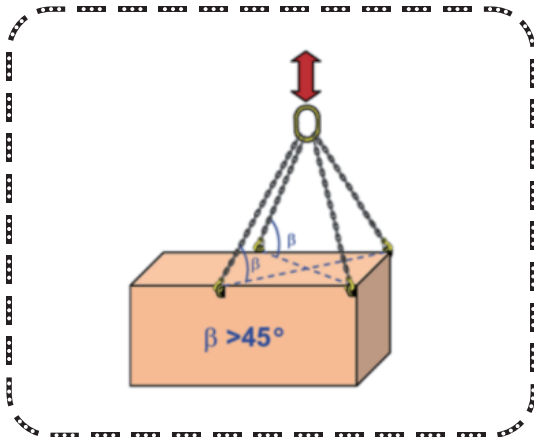
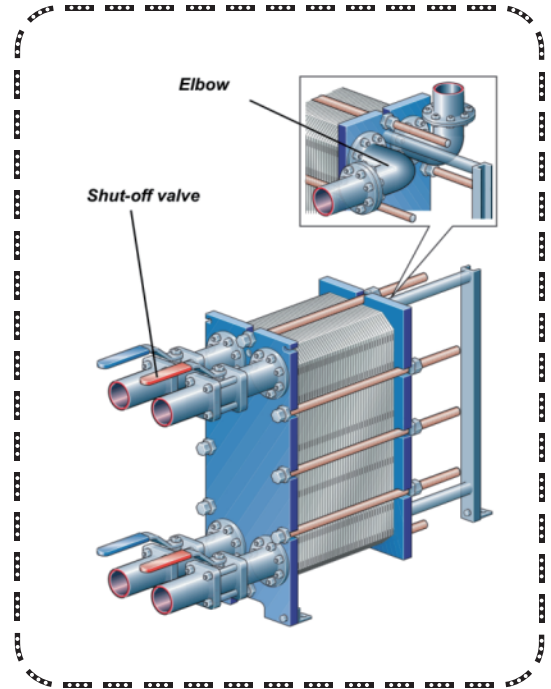

Lifting

Straps should be used when lifting the SWHE. Position straps as illustrated. The straps shall be attached as illustrated and with a minimum angle of 45° . See illustration below.



Warning!
Never lift by the connectors or studs.



Lifting device for small unit

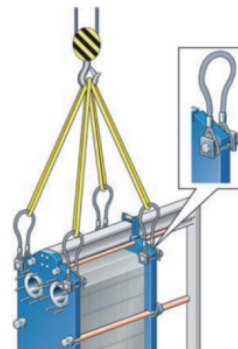

Lifting device for large unit

Raising

This instruction is valid when raising the SWHE after delivery from HFM. Strap approved for the weight of the heat exchanger to be used.



Caution!
The straps shall be long enough to rotate the PHE without obstructions.
Pay particular attention to the space required for the support column.

1. Place two timber posts on the floor.

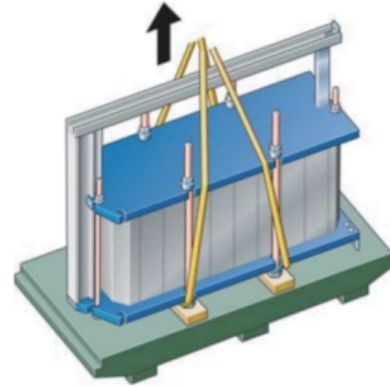
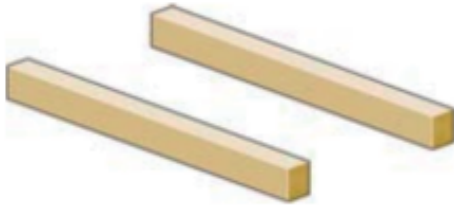

2. Lift the SWHE off the pallet using e.g. straps.

3. Position the SWHE on the timber posts.

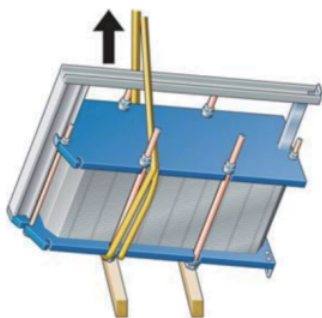
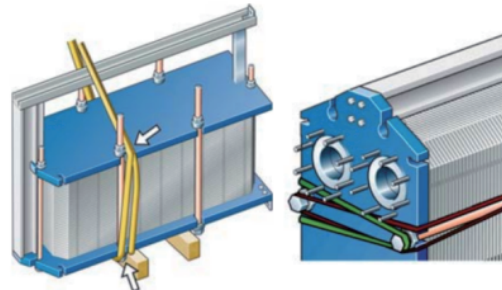
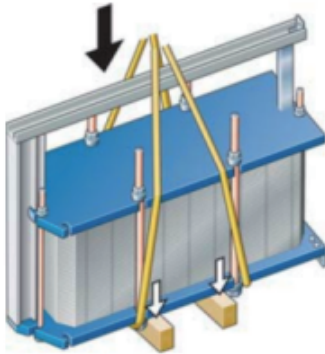

5. Lift the SWHE off the timber posts.

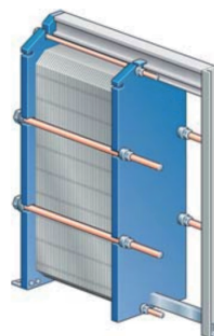

6. Lower the SWHE onto the floor in a horizontal position.

Connecting to system

- Remove sealing blind covers from the port holes before connecting the piping system.
- When connecting the piping system, make sure the pipes do not subject the SWHE to stress or strain.
- Before connecting any piping, make sure that no foreign objects have been left in the system that should be connected to the SWHE. It is recommended to install a strainer or filter with 0.5-1.0 mm mesh size to prevent problems with foreign objects in the piping system.

Start-up



Note!

Adjustments of flow rates should be made slowly in order to avoid the risk of pressure surge (water hammer).

Water hammer is a short-lasting pressure peak that can appear during start-up, or shut-down of a system, causing liquids to travel along a pipe as a wave at the speed of sound. This can cause considerable damage to the equipment.



Note!

Charging liquid ammonia into a refrigeration circuit under vacuum will result in low temperatures. Such temperature levels might be lower than any elastomeric materials can seal against.

In applications where the field side is used for a two-phase refrigerant e.g. cascade CO₂/NH₃ applications, it is very important to fill the two-phase refrigerant in gas phase. This to avoid temperature chocks for the gaskets and to avoid temporary leakages due to the natural fact that the metal is shrinking very fast.

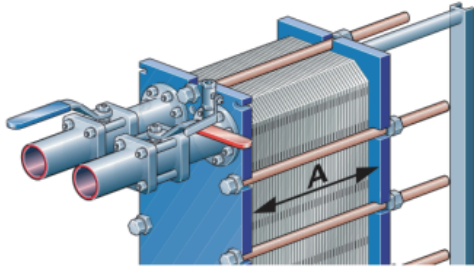

1. Before start-up check that all tightening bolts are firmly tightened and that the dimension A is correct. See SWHE drawing or name plate.

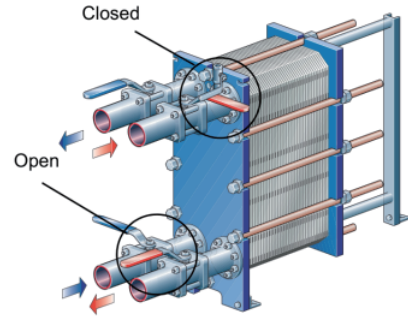

2. Check that the valve is closed between the pump and the unit controlling the system flow rate.

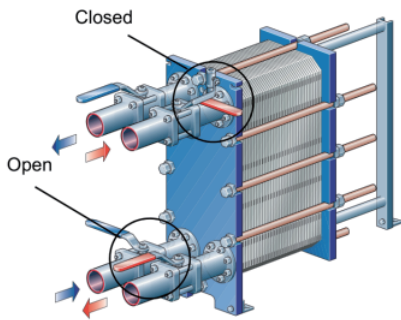

3. If there is a valve at the exit, make sure it is fully open.

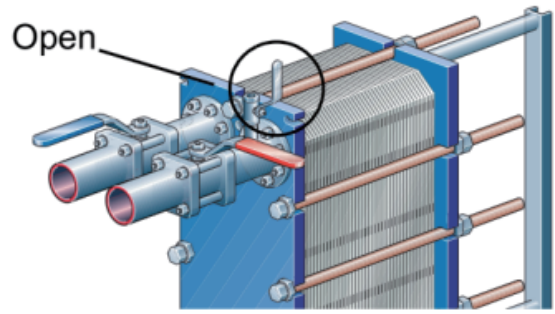

4. Open the air vent and start the pump.

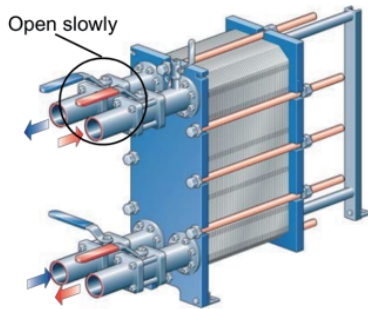

5. Open the valve slowly.

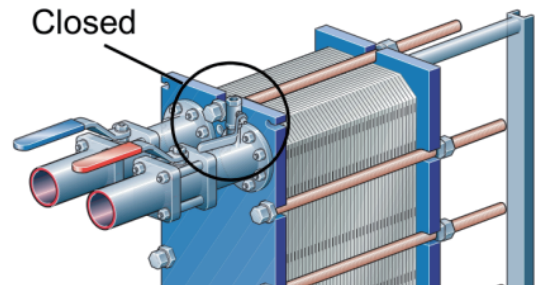

6. When all air is expelled, close the air vent.

7. Repeat steps 1 - 6 for the second media.

Unit in operation



Note!

Adjustments of flow rates should be made slowly in order to protect the system against sudden and extreme variations of temperature and pressure.

Shut-down

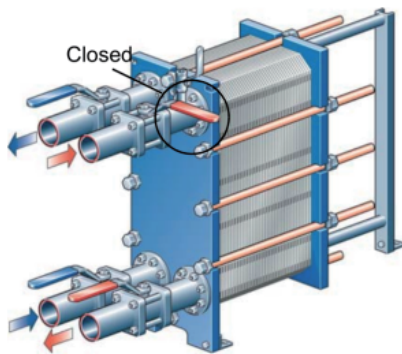

1. Slowly close the valve controlling the flow rate of the pump you are about to stop.

2. When the valve is closed, stop the pump.

3. Repeat steps 1 - 2 for the other side for thesecond media.

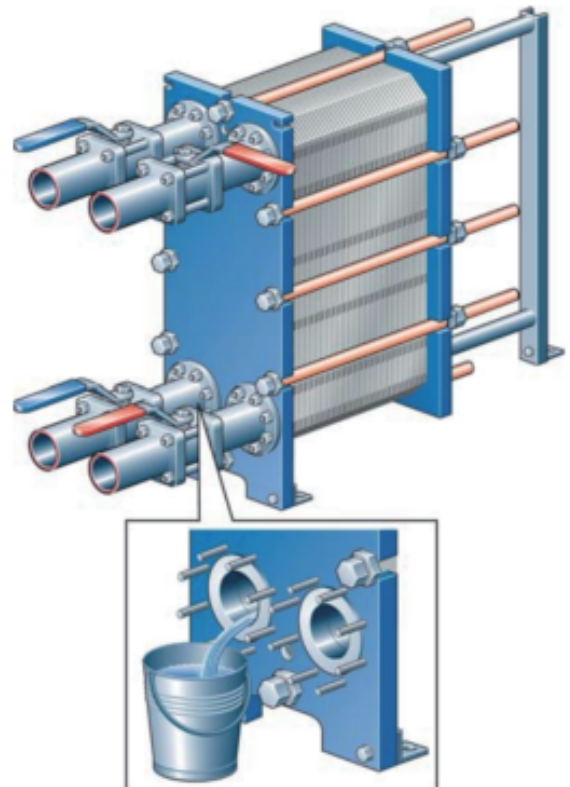

4. If the SWHE is shut down for several days or longer, it should be drained. Draining should also be done if the process is shut down and the ambient temperature is below the freezing temperature of the media. Depending on the media processed, it is also recommended to rinse and dry the heat exchanger cassettes and connections.

Maintenance



Note!
When cleaning within the process it is strongly recommended to use modulating or soft pumps to avoid high flow rates and pressure shocks.



Note!
Always evacuate or drain the refrigerant before starting up maintenance or Cleaning-In-Place.



Note!
After a extended use, the SWHE gaskets may need replacing

Cleaning-In-Place (CIP)

The Cleaning-In-Place (CIP) equipment permits cleaning of the PHE without opening it. Benefits CIP:

- Removal of fouling and lime scale deposits.
- Passivation of cleaned surfaces to reduce susceptibility to corrosion.
- Neutralisation of cleaning liquids before draining. See CIP equipment instructions.

If CIP is appropriate, choose the appropriate cleaning solution based on the type of scale. Usually, acidic cleaning solution is used to remove dirt, rust, and other debris. And alkaline cleaning solution is used to remove paint, grease, oil and biological deposits.



Note!
When using CIP to clean heat exchangers, it is strongly recommended to verify whether the cleaning solution used will cause damage to the plate and gasket.

If CIP is inappropriate, cleaning must be done manually.

Manual cleaning

To perform manual cleaning it is required to open the SWHE and lift out the cassettes to clean them. Only gasketed side is feasible to clean.

Opening



Note!
Before opening the PHE check the warranty conditions.



Warning!
If the Plate Heat Exchanger is hot, wait until it has cooled down to about 40°C(104°F).



Warning!
If necessary, use proper protective equipment, such as safety boots, safety gloves and eye protection, depending on type of media in the PHE.

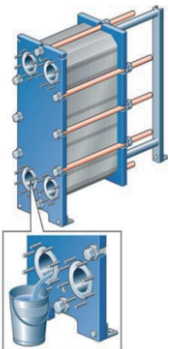

1. Drain the Semi-Welded Plate Heat Exchanger.

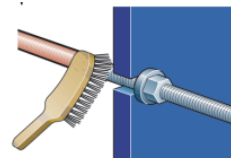

2. Brush the threads of the bolts clean, using a steel wire brush. Lubricate the threads with a thin layer of grease, e.g. Gleitmo 800 Lubriplate or equivalent.

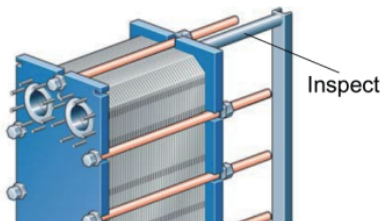

3. Inspect the sliding surfaces of the carrying bar and clean and grease it.

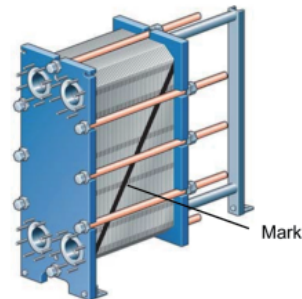

4. Mark the cassette assembly on the outside with a diagonal line.

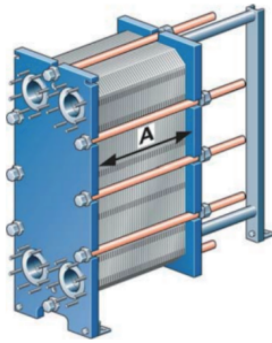

5. Measure and note the dimension A.

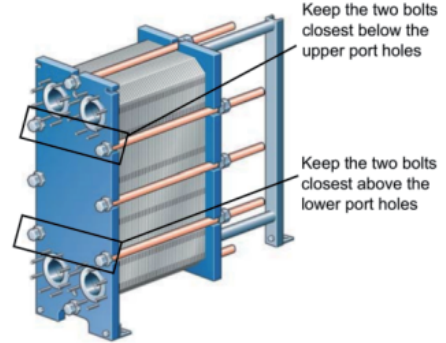

6. Keep the four bolts in position, according to the figure below. Loosen the other bolts and remove them.

7. The remaining four bolts are opened alternately and diagonally in two steps, see figures below. Be careful to ensure that the frame plate and pressure plate are always parallel. Skewing of the pressure plate during opening must not exceed 10 mm (2 turns per bolt) across the width and 25 mm (5 turns per bolt) vertically.

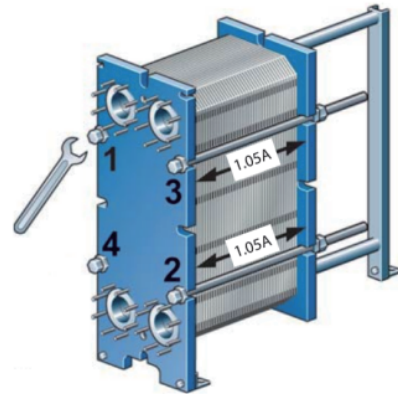

Step 1: Loosen the four bolts alternately and diagonally until the plate package measures 1.05A.

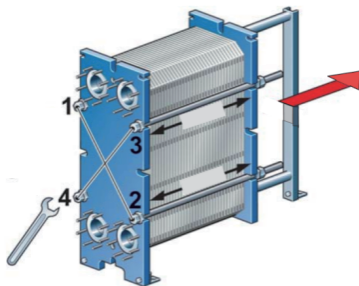

Step 2: Loosen the two diagonal pairs of bolts alternately, as shown in the figure below.

8. Open the plate pack by letting the pressure plate glide on the carrying bar.

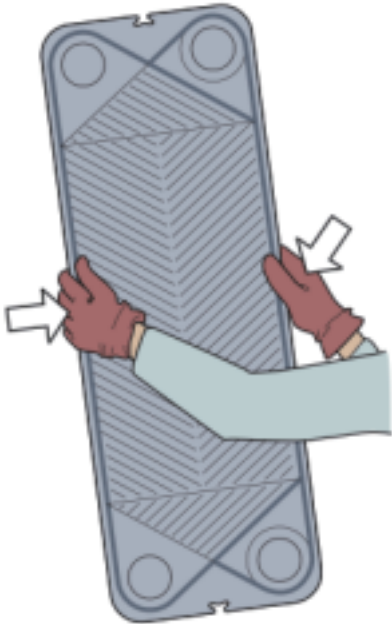

Warning!
If necessary, use proper protective equipment, such as safety boots, safety gloves and eye protection, depending on type of media in the PHE.



Note!
Cassettes should be numbered, do this before removing the cassettes.

Cassettes do not need to be removed if cleaning is done using only water, i.e. without cleaning agent.

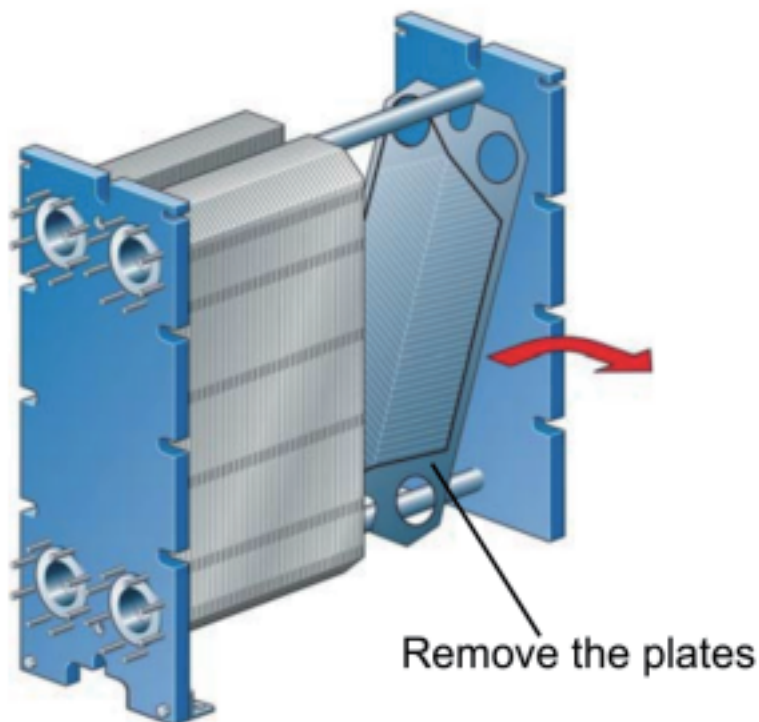



Warning!

The plate pack may still contain a small residual amount of liquid after draining.

Depending on the type of product and type of installation, special arrangements, e.g. drainage box, may be necessary to avoid injury to personnel and damage to equipment

Manual cleaning of opened units



Caution!

Never use hydrochloric acid with stainless steel plates. Water of more than 330 ppm Cl may not be used for the preparation of cleaning solutions.



Note!

Be careful not to damage the gasket during manual cleaning.

Deposits removable with water and brush

Cassettes do not need to be removed from the PHE during cleaning.

1. Start cleaning when the heating surface is still wet and the cassettes are hanging in the frame.

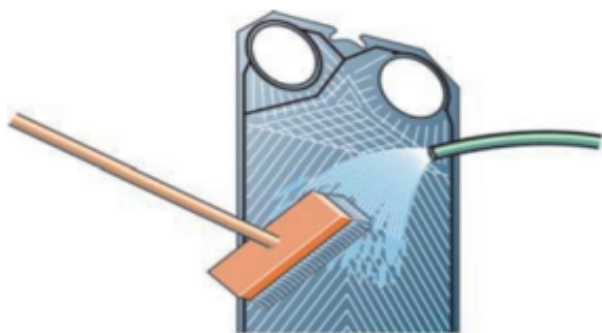

2. Remove deposits using a soft brush and running water.



3. Rinse with water using a high pressure hose.

Deposits not removable with water and brush

Cassettes must be removed from the PHE during cleaning.



Warning!

Use proper protective equipment, such as safety boots, safety gloves and eye protection, when using the cleaning agents.

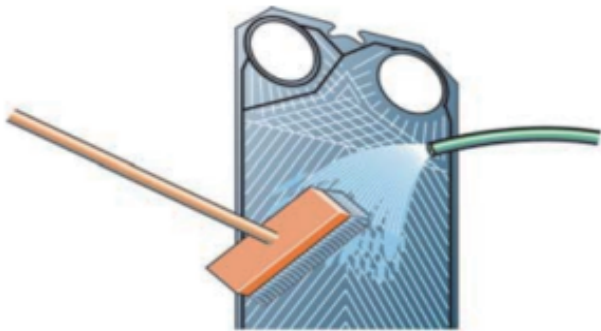

1. Brush with cleaning agent.



2. Rinse immediately with water.

Regasketing

The procedures below apply to Field gaskets and Ring gaskets affixed to the cassettes using glue free Clip-on type.



Note!

Before removing the old gaskets check how they are placed and attached. Especially the end cassette gasket configuration needs attention.

Clip-on type gasket

1. Open the SWHE and remove the cassette that is to have a new gasket.

2. Remove the old gasket.

3. Ensure that all sealing surfaces are dry, clean and free of foreign matter such as fat, grease or similar.

4. Check the gasket and remove rubber residual before attaching it.

5. Attach the Clip gasket to the cassette. Slip the gasket prongs under the edge of the plate. Fix the field gasket diagonal using 3M glue on the the small tabs.

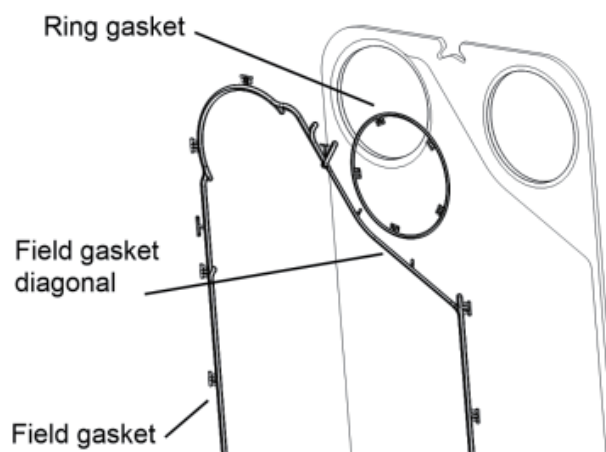

6. Repeat the procedure until all cassettes that are needed to be regasketed are done. Close the SWHE according to "Closing".



Note!

The clip-on gasket can also be fixed using 3M glue. It depends on the specific condition of the heat exchanger you receive.

Clip-on type gasket

The procedures below apply to Field gaskets and Ring gaskets affixed to the cassettes using glue.



Caution!
Try to use 3M glue as much as possible. Other types of glues may cause damage to the gasket and plate.

- | |
|---|
| 1. Open the SWHE and remove the cassette that is to have a new gasket. |
| 2. Remove the old gasket and the remained glue. |
| 3. Ensure that all sealing surfaces are dry, clean and free of foreign matter such as fat, grease or similar. |
| 4. Apply 3M glue to the original gasket position of the cassette. |
| 5. Attach the gasket to the cassette. In order to firmly adhere the gasket to the cassette, let it stand for more than 10 minutes before putting the cassette into use. |
| 6. Repeat the procedure until all cassettes that are needed to be regasketed are done. Close the SWHE according to "Closing". |

Closing

Follow the instructions below to ensure that the Semi-Welded Plate Heat Exchanger will be properly closed.

1. Check that all the sealing surfaces are clean.

2. Brush the threads of the bolts clean, using a steel wire brush. Lubricate the threads with a thin layer of grease, e.g. Gleitmo 800 Lubriplate or equivalent.

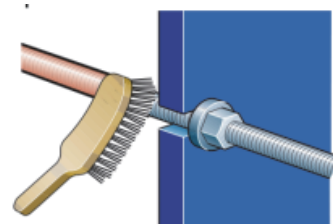

3. Attach gaskets to the cassettes or check that all the gaskets are properly attached.

4. Use the marked line that was done when the SWHE was opened to insert the cassettes.

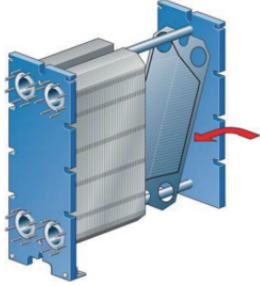

5. If the cassettes are correctly assembled, the edges form a "honeycomb" pattern, see picture below.

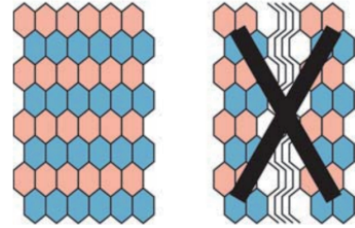

6. Press the plate assembly together. Tightening is done in two steps, see figures below. Be careful to ensure that the frame plate and the pressure plate are always in parallel.

Step 1: Tighten the two diagonal pairs of bolts alternately until the plate package measures 1.10A.

Be careful to ensure that the frame plate and pressure plate are always in parallel.

Skewing of the pressure plate during closing must not exceed 10 mm across the width and 25 mm vertically.

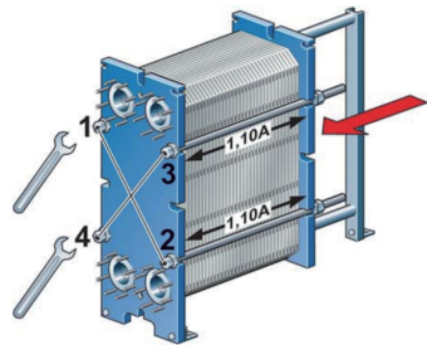

Step 2: After that, bolts are tightened alternately and diagonally, as shown in the figure below. Check the dimension A during tightening at the positions of the bolts that are being used.

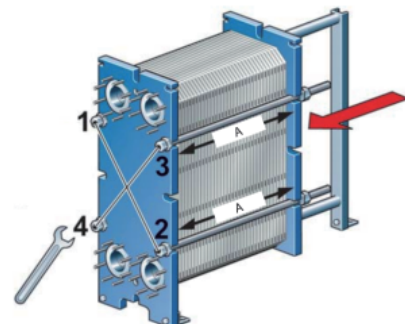



Note!
The final tightening to reach dimension A is recommended to be divided into steps.

Max tightening torque

Bolt size	Bolt with washers N·m
M20	265
M24	450
M30	900
M39	2000
M48	3300

If dimension A cannot be reached

- Check the number of cassettes and the dimension A.
- Check that all the nuts are running freely. If not, clean and lubricate, or replace.
- Leave the SWHE between 24-48 hours, the longer the better, for gaskets to relax.

7. Place the other bolts in position.
- Inspect the washers.
 - When fully tightened, the bolts should all be equally tensioned.

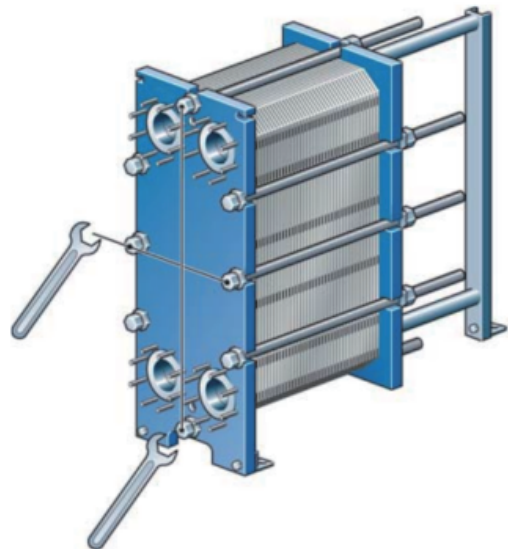

Before start-up of production, whenever cassettes or gaskets have been removed, inserted or exchanged, it is strongly recommended to perform a pressure test to confirm the internal and external sealing function of the SWHE. During this test, one media side at a time must be tested with the other side open to the ambient pressure.



Caution!

The pressure testing shall be performed at a pressure equal to the operating pressure of the actual unit, but never above the design pressure as stated on the nameplate after maintenance.

The recommended test time is 30 minutes for each media. Always check that the local regulations of this procedure are fulfilled.

Please note that SWHE units for refrigeration applications and units with media not mixable with water must be dried after hydrostatic pressure testing.

Storage of the SWHE

HFM delivers the SWHE ready to be put into service upon arrival if nothing else has been agreed. However, keep the heat exchanger in the packing box until installation. Regarding storage for longer periods of time, one month or more, certain precautions should be made to avoid unnecessary damage to the SWHE.

Storage in packing box

Indoor storage

- Store inside a room with the temperature between 15 and 20°C (60 - 70°F) and humidity around 70%. For outdoor storage read “Outdoor storage” on this page.
- To prevent damage to the gaskets, there should not be any ozone-producing equipment in the room such as electric motors or welding equipment.
- To prevent damage to the gaskets, do not store organic solvents or acids in the room and avoid direct sunlight, intensive heat radiation or ultraviolet radiation.
- The tightening bolts should be well covered with light grease coating.

Outdoor storage

If the SWHE has to be stored outdoors, all the precautions mentioned in the section “Indoor storage” on this page should be taken. Also, protection against climate is very important.

The stored heat exchanger shall be visually checked every third month. The check includes:

- Greasing of the tightening bolts
- Metal port covers
- Protection of the plate pack and gaskets

Long time storage

If the SWHE has to be stored for a long period of time, follow the same advice as in the previous sections. At long term storage, the SWHE has to be filled with inert gas (like N₂) in order to keep the gaskets in good condition by preventing moisture and oxygen to reach the gaskets.

Installation after long-term storage

In cases when the SWHE has been taken out of service for an extensive period of time, i.e. longer than one year, the risk of leakage when starting up increases. To avoid this problem it is recommended to let the gasket rubber rest and regain most of its elasticity.

1. Note the measurement between frame and pressure plate (A dimension).
2. Remove feet attached to the pressure plate(if any).
3. Loosen the tightening bolts. Follow the instructions "Opening" . Open the SWHE until the measure is 1.25A.
4. Leave the SWHE between 24-48 hours, the longer the better, for gaskets to relax.
5. Re-tighten according to the instructions "Closing".
6. HFM recommends a leakage test to be carried out.
7. For refrigeration applications and units with media not mixable with water must be dried after hydrostatic pressure testing (if any).

HFM



Follow us on



Hofmann (Beijing) Engineering Technology Co., Ltd.

 www.hofmann-heatexchanger.com

 +86(10)84478229

 service@hfm-phe.com

 3F/6F Zhengdong International Mansion,
100027, Dongcheng District, Beijing, China